

POSITIONER

H. Tracy Hall

12 JAN 1966

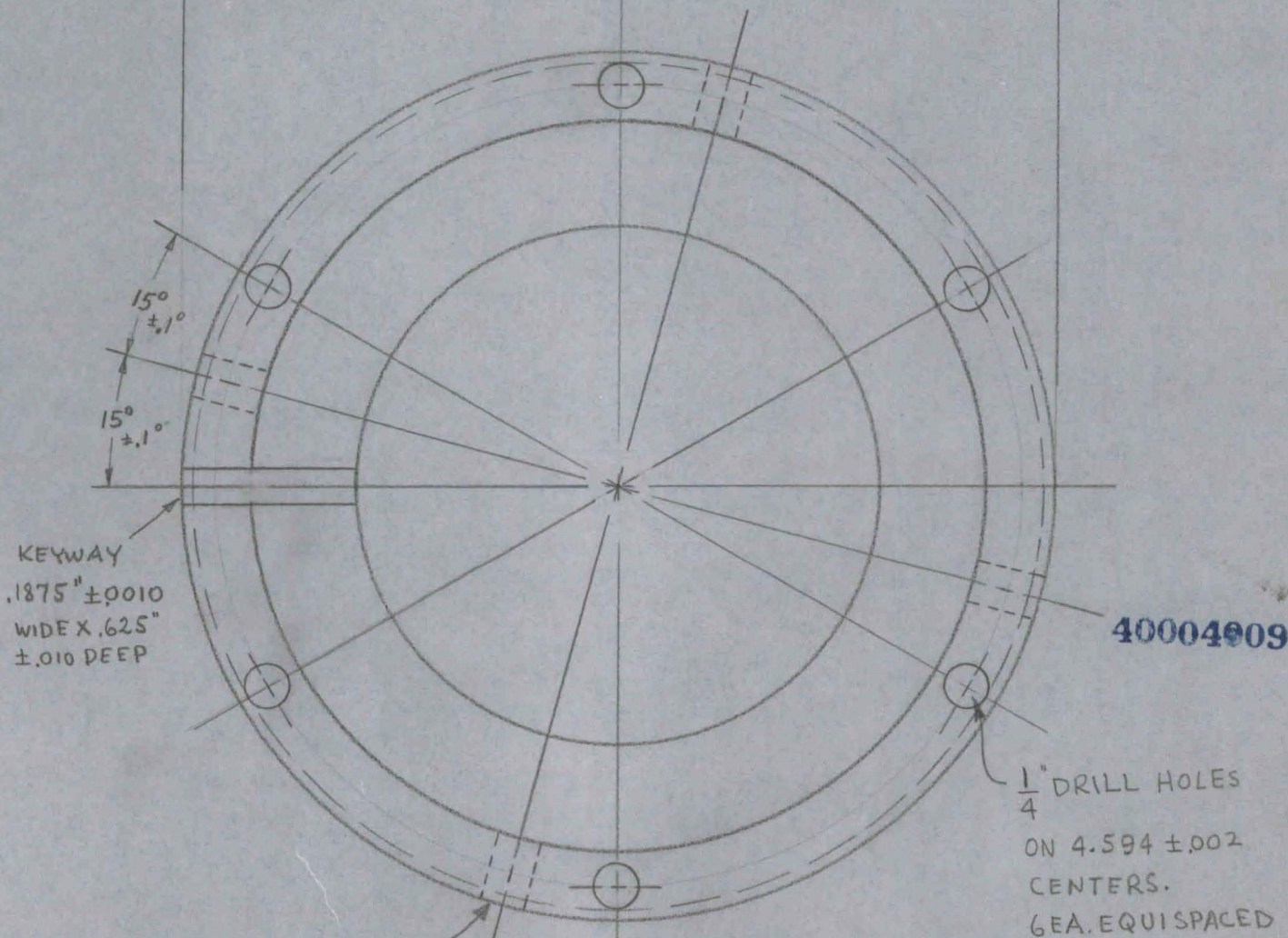
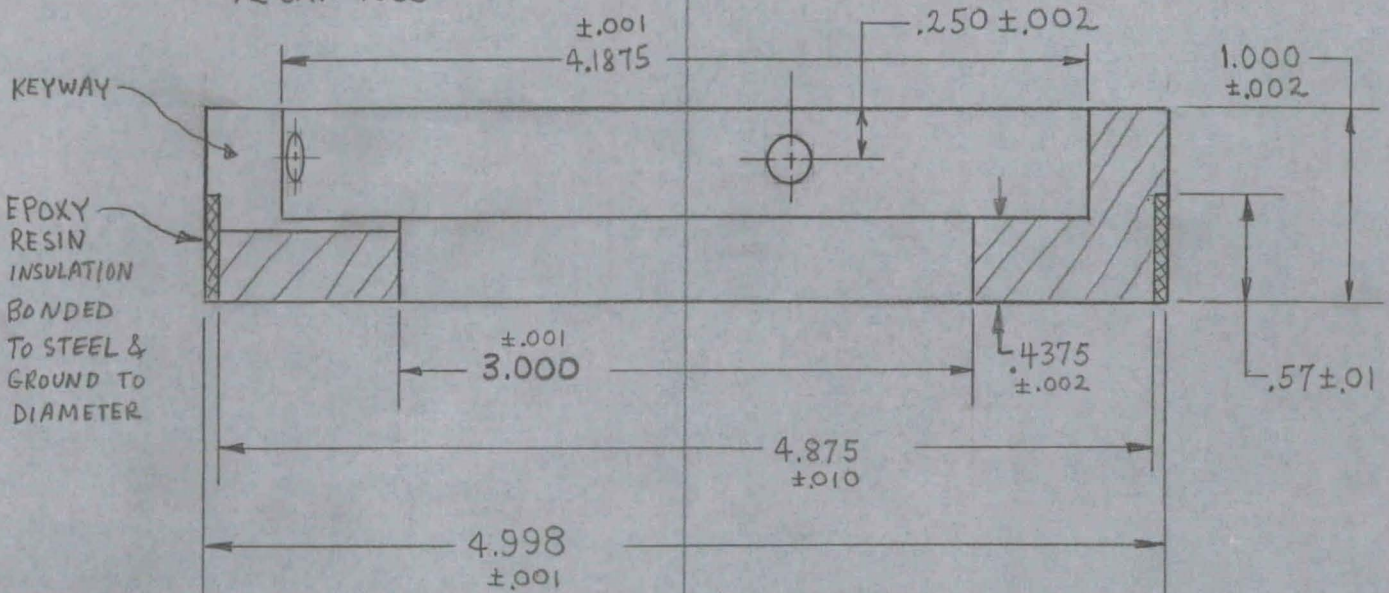

1/4 - 20 THD.
4EA. EQUISPACED
FOR SETSCREWS

CONFIDENTIAL
THIS DOCUMENT IS SUBJECT TO COURT ORDER
MAKE OF STEEL
OF HARDNESS R_c 28/32

GUIDE PLATE

H. J. Hall
12 Jan 1966

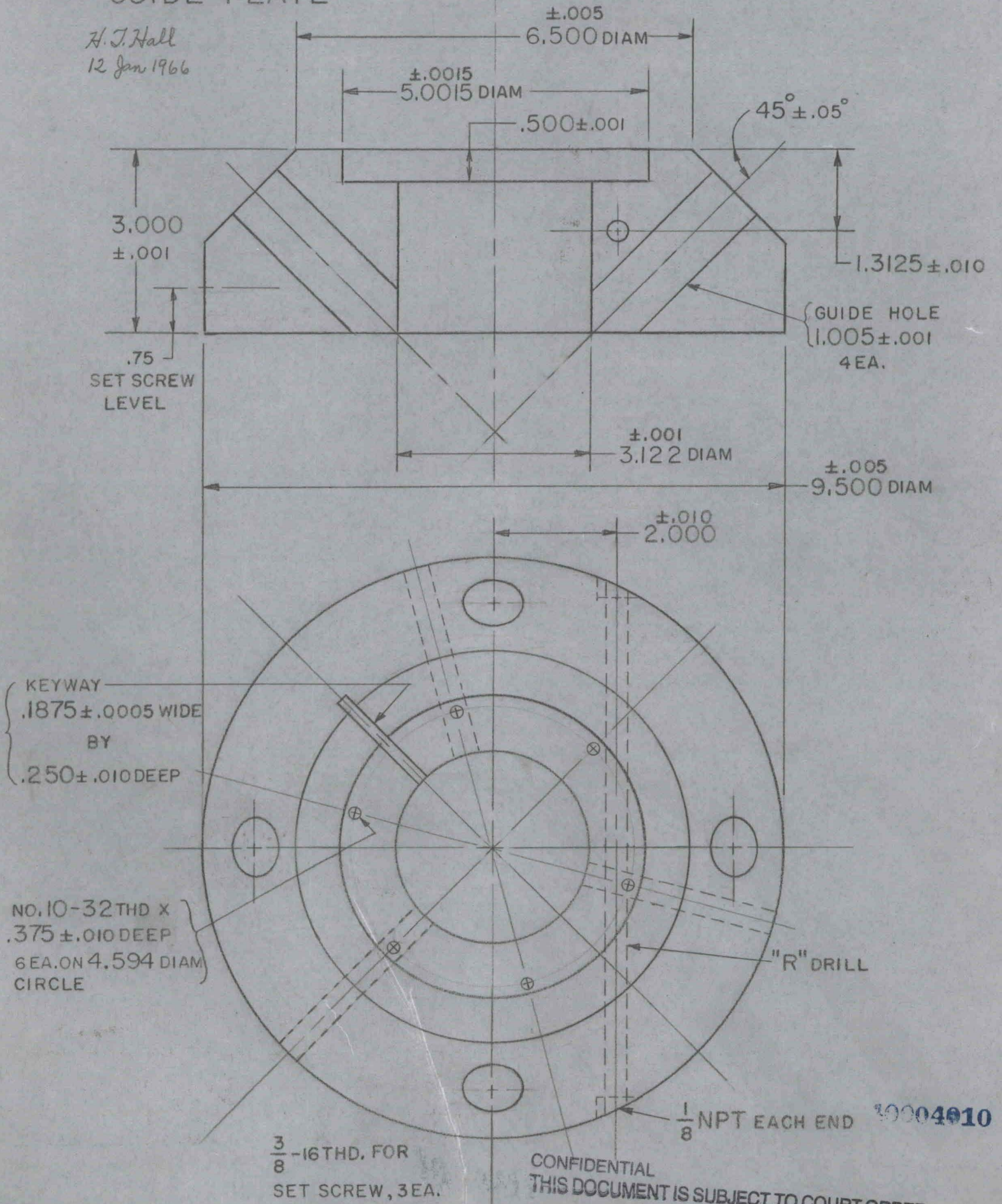

CONFIDENTIAL
THIS DOCUMENT IS SUBJECT TO COURT ORDER
MAKE OF HARD ALUMINUM
WITH MINIMUM YIELD > 50,000 PSI

10004010

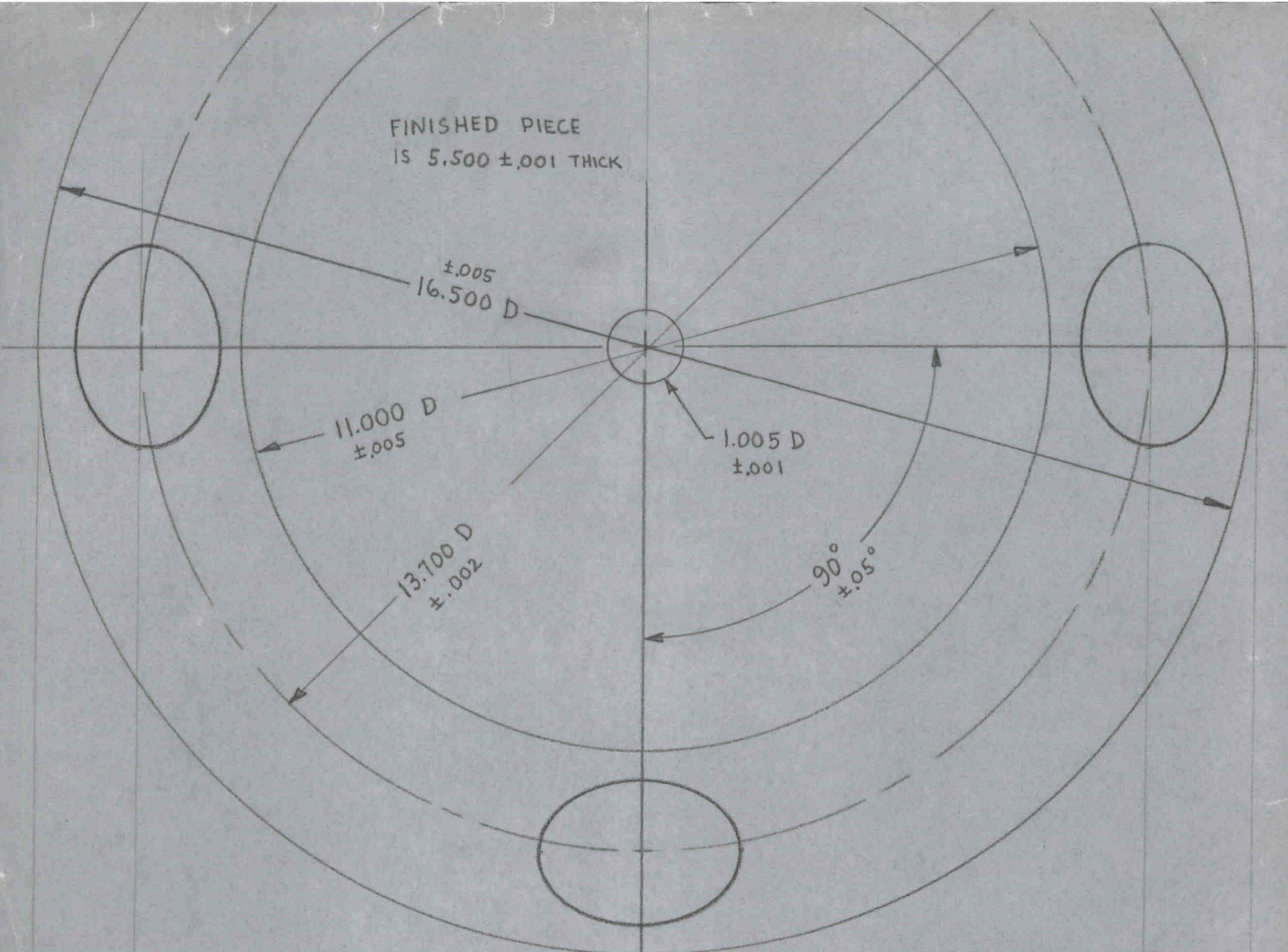

RAM BASE

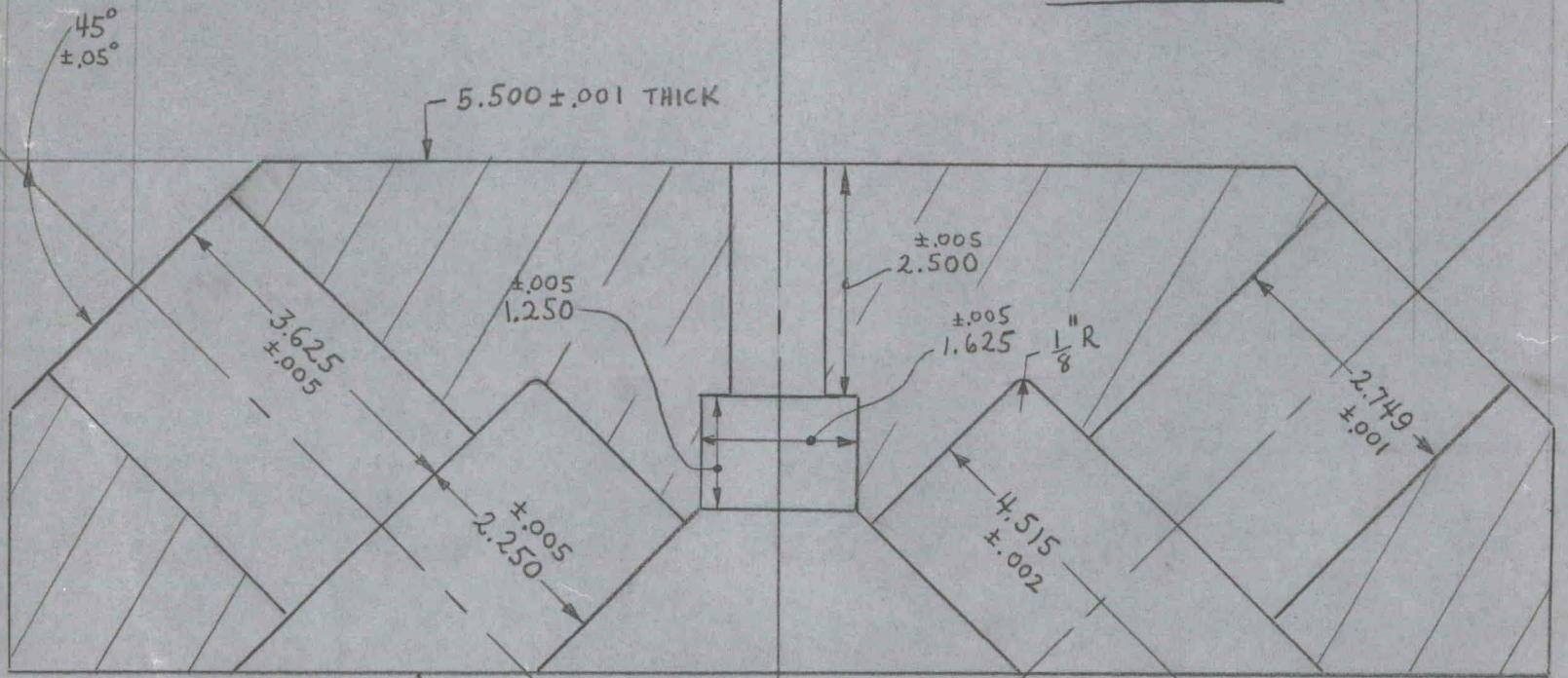

RAM BASE, 200 TON CUBIC P.
HARDNESS Rc 28/32
MAKE OF 4340 STEEL FORGING
AIRCRAFT QUALITY, MAGNAFLUXED

40004911

6EA. REQ'D.
H. Tracy Hall 13 JAN 1966

CONFIDENTIAL
THIS DOCUMENT IS SUBJECT TO COURT ORDER